

# LAB01

## Manual Label Applicator

### ITEMS INCLUDED

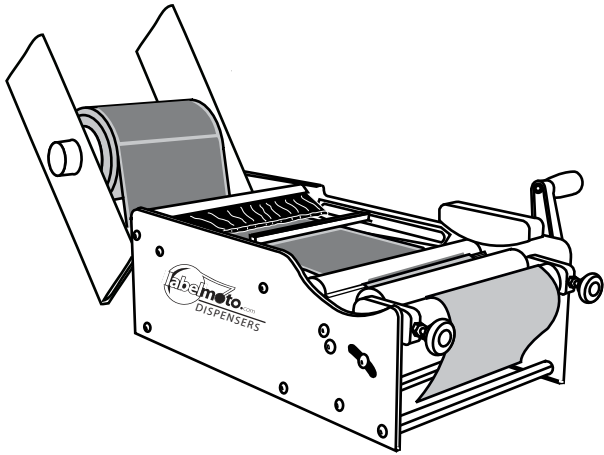

Dispenser

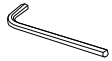

Hex Wrench

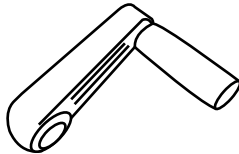

Handle

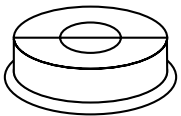

Core Holder (2)



Reel Guide (2)

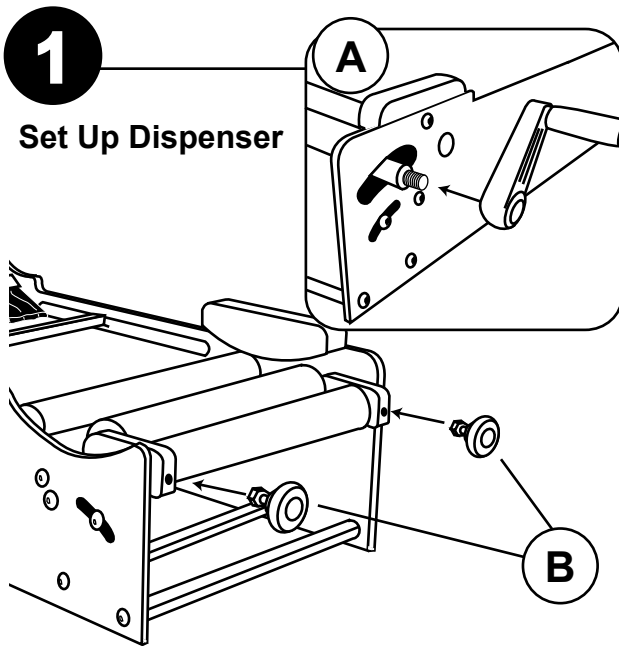

- 1** Set Up Dispenser
- A:** Install handle onto feed roller  
**B:** Install and tighten the thumb screws

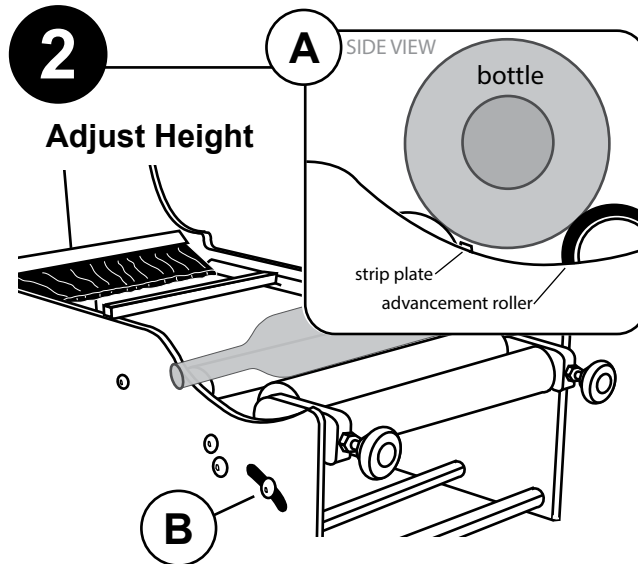

- 2** Adjust Height
- A:** Place bottle onto rollers and adjust screws with hex wrench to position rollers until bottle rests 1 - 2mm above strip plate  
**B:** Tighten screws on both sides and remove your bottle

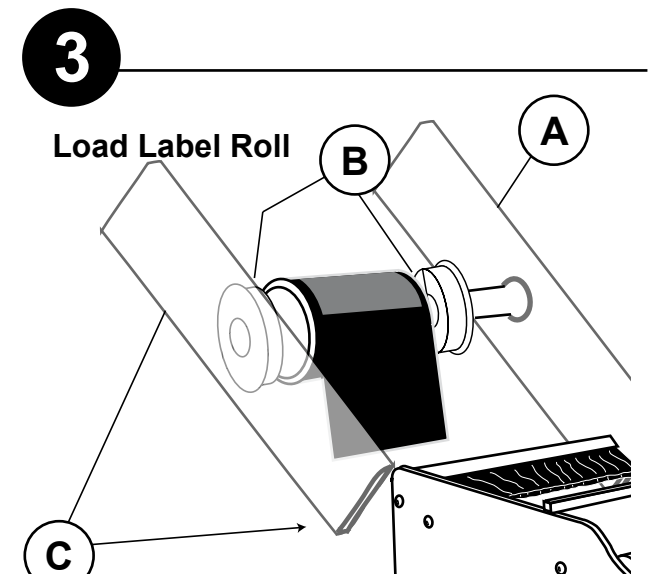

- 3** Load Label Roll
- A:** Slide reel guide onto the hanger bar  
**B:** Insert core holders into your label roll and slide loaded roll onto reel hanger bar  
**C:** Slide other reel guide onto the hanger bar

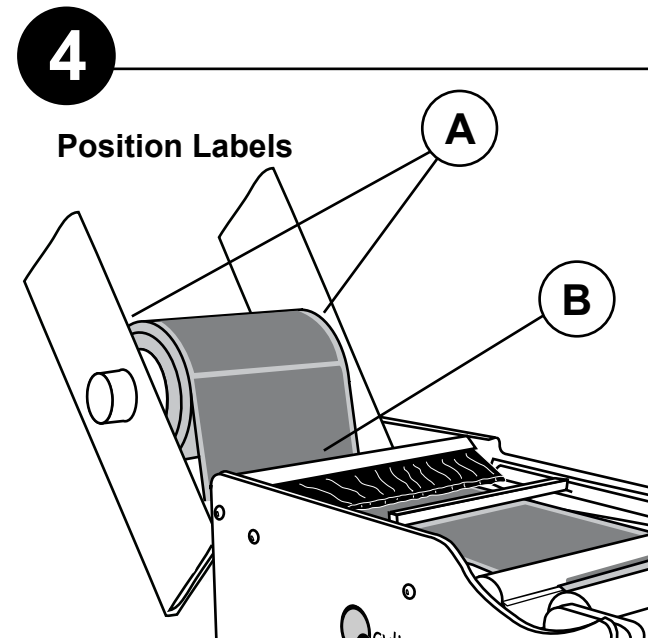

- 4** Position Labels
- A:** Position label roll for desired placement and tighten thumb screws  
**B:** Feed label liner under guide bar and brush

5

Continue Feeding Label Liner

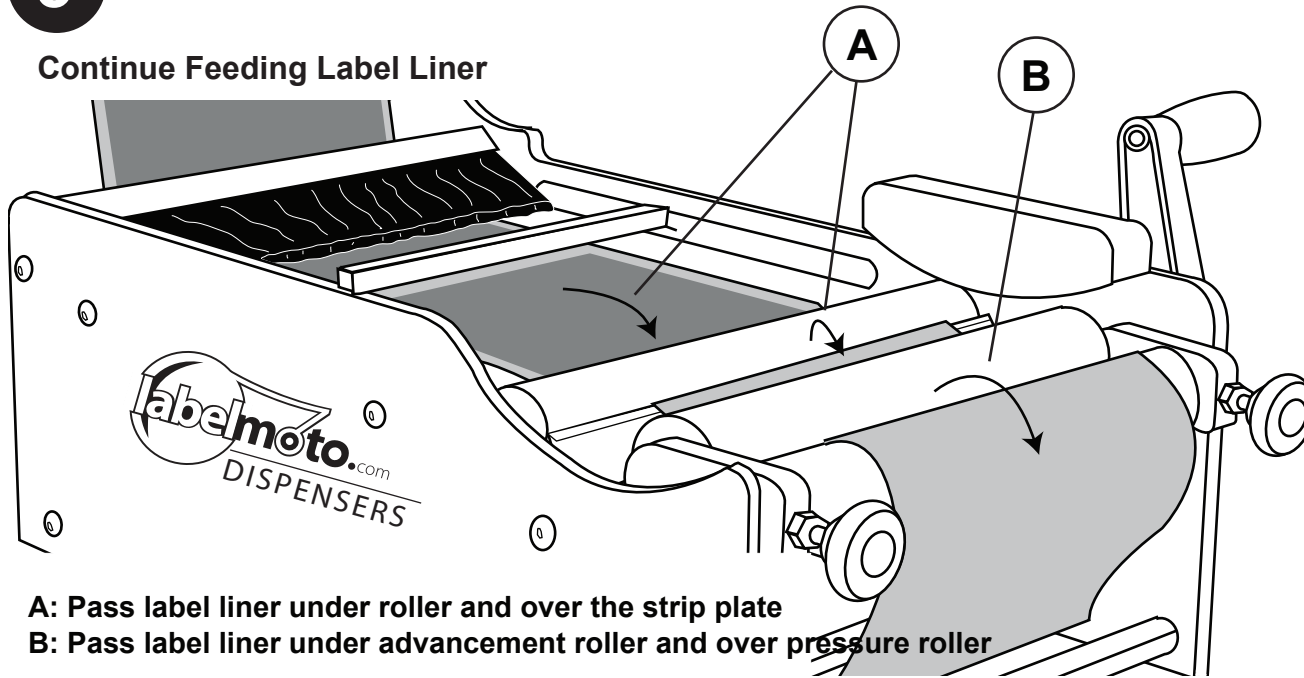

- A: Pass label liner under roller and over the strip plate
- B: Pass label liner under advancement roller and over pressure roller

6

Set Label

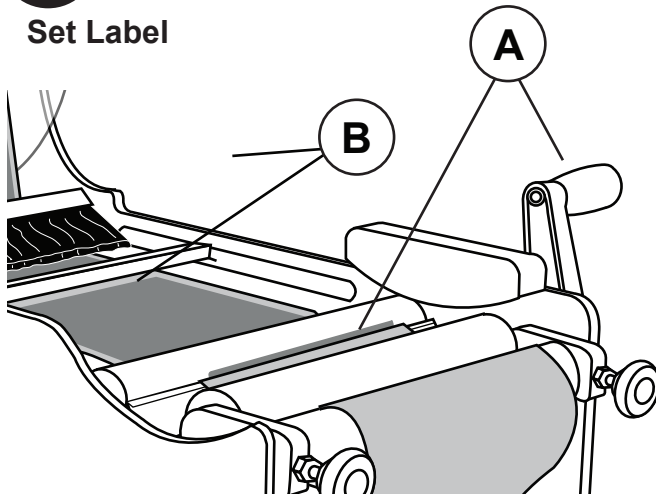

- A: Turn handle until edge of label is 2mm above strip plate
- B: Position guide marker directly over the gap between labels

7

START Labeling

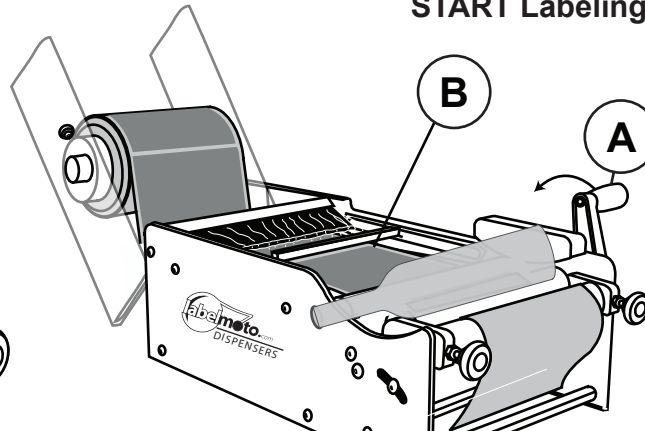

- A: Place your bottle on the rollers and rotate handle to apply label
- B: Stop turning when guide marker is over gap in next label

Need more help? Download the full manual or contact us

LAB01



Quick Start Guide

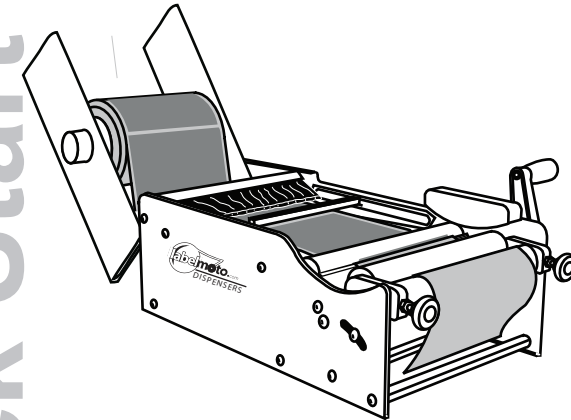

4270 Airborn Dr, Addison, TX 75001, USA  
972.248.1999 | tech@startinternational.com

▶ [STARTinternational.com](http://STARTinternational.com)